

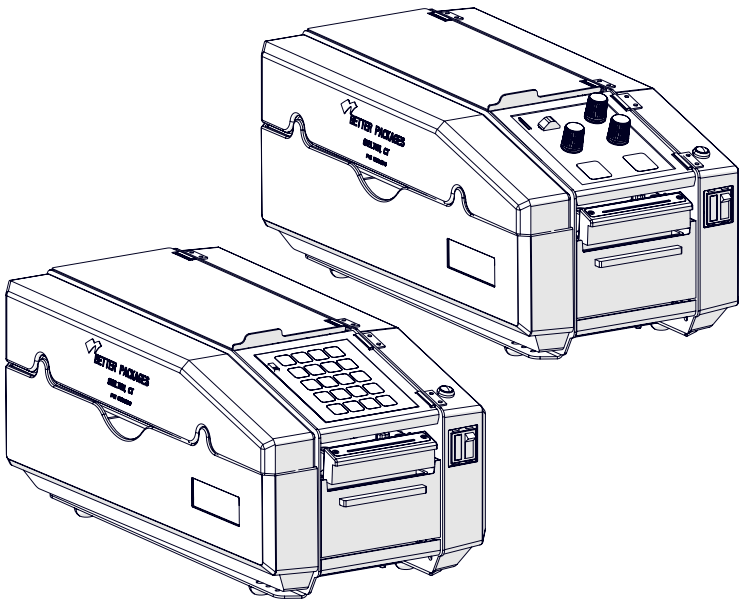

# USER MANUAL 755E SERIES



# USER NOTES

---

For all IPG product manuals please visit [www.itape.com/systems-manual](http://www.itape.com/systems-manual) or use this QR code



# TABLE OF CONTENTS

---

<b>Technical Assistance</b>	<b>4</b>
Replacement Parts	4
<b>Warranty Information</b>	<b>5</b>
Warranty Registration	6
<b>General Information</b>	<b>7</b>
Description of the 755e	7
Definitions	7
<b>Important Safeguards</b>	<b>8</b>
<b>Label Placement</b>	<b>9</b>
<b>Label Descriptions</b>	<b>10</b>
<b>Machine Nameplate</b>	<b>11</b>
<b>Important Safeguards</b>	<b>12</b>
Explanation of Signal Word Consequences	12
Operator Skill Level Descriptions	13
<b>Specifications</b>	<b>14</b>
755e Dimensions	14
755e Components	15
Operating Conditions	16
Tape Requirements	16
Technical Specifications	16
Tape Length	16
<b>Set-up Procedure</b>	<b>17</b>
Unpacking	17
Verifying the Contents	17
Adjusting the Roll Guides	17
Loading the Tape Gum Side In	18
Checking the Upper Tape Plate	19
Installing the Brushes and Water Tank	20
Adjusting the Water Level	20
Water Tank Install	21
Water Bottle Install	22
Connecting Power and Utilities	23
Setting and Adjusting Temperature	24
<b>Operation</b>	<b>25</b>
General Operating Procedures	25
Selecting the Length of Tape 755eS and 755eM	25
Selecting the Length of Tape 755eSA and 755eMA	26
Random Button	26
<b>Applying Tape to a Carton</b>	<b>27</b>
Choosing the Correct Tape Type	27
Choosing the Correct Tape Length	27
Proper Tape Moistening	27
<b>Applying Tape to a Carton</b>	<b>28</b>
Sealing the Carton	28
Common Tape Patterns	28
<b>Preventative Maintenance</b>	<b>29</b>
Suggested Preventative Maintenance Schedule	29
Washing the Tank, Brush, and Bottle	29
<b>Troubleshooting</b>	<b>30</b>

# TECHNICAL ASSISTANCE

---

This is the **Better Packages Model 755e Series** WAT Dispenser you ordered. It has been set up and tested in our factory with IPG manufactured water activated tapes. If any problems occur when setting up or operating this equipment, please contact the authorized distributor from where you purchased this dispenser.

If contact with the authorized distributor is not possible, **IPG Machinery Support** is available. Should the need to contact **IPG Machinery Support** arise, **please have the equipment model and serial number available prior to contact**. This information can be found on the nameplate of the Dispenser. A section at the bottom of this page is available to write this information down. **IPG Machinery Support** is available during normal business hours (M-F 8am-7pm) Eastern Time.

Phone: +1 813-345-3070

Email: [machsupp@itape.com](mailto:machsupp@itape.com)

## **Replacement Parts**

A breakdown of parts, including part numbers, can be provided upon request. If you know the part number that you require please contact your authorized distributor or Better Packages Customer Service 1-203-926-3700 or 1-800-237-9151 (United States only), parts can also be found directly at [www.betterpackages.com/parts](http://www.betterpackages.com/parts)

Please use this area to enter the detailed information on your dispenser. This should be filled out at the time of install. This information can be found on the nameplate of the machine, next to the main power plug on the back of the dispenser.

## **Machine**

### **Model**

### **Serial**

### **Distributor**

### **Name**

### **Phone/Email**

### **Date of Purchase**

# WARRANTY INFORMATION

---

## Better Packages, Inc. Limited Warranty

Better Packages warrants each new machine and accessory to be free from defects in materials and workmanship under normal and proper use conditions. The following warranty periods from date of purchase apply:

Model	Parts	Labor
Better Pack 755e Series	2 Years	6 Months
Better Pack 555e Series	2 Years	6 Months
Better Pack 500 Series	2 Years	6 Months
Better Pack 333 Series	2 Years	6 Months
Better Pack PS2A	1 Year	6 Months
Curby Mini Taper (BP222)	1 Year	6 Months
Packer 3S	2 Years	6 Months
Tape Shooter 404	2 Years	6 Months
Auto H2O Series	1 Year	6 Months

Wearable parts such as shear blades, water brushes, motor brushes, **side guide plates and upper tape guide plates** are not covered under the warranty. The following wearable parts are warranted for 3 months from date of purchase:

1. Main Board
2. Solenoid
3. Main Motor

### Warranty Conditions and Exclusions

Machines and accessories used for any improper or unintended purpose will not be considered for warranty protection. Any modification of the machines or accessories shall make this warranty null and void. Use of replacement parts other than genuine Better Packages replacement parts shall also make this warranty null and void.

Better Packages shall have no obligation to repair or replace (1) those parts failing due to operator misuse, carelessness, or due to any accidental cause other than equipment failure, or (2) parts that fail due to:

1. Misapplication, lack of proper maintenance, abuse, improper installation, or abnormal conditions such as temperature, moisture, dirt, or corrosive matter, etc.
2. Inadequate cleaning, improper operating environment, improper utilities, or operator error.
3. Operations beyond the rated capacity of the product.
4. Alteration or servicing of the product by anyone other than an authorized representative of Better Packages.
5. Any attempt by the purchaser to repair or correct alleged defective equipment. In this event the purchaser is responsible for all expenses incurred.

**IN NO EVENT SHALL BETTER PACKAGES BE LIABLE FOR ANY INDIRECT, INCIDENTAL OR CONSEQUENTIAL DAMAGE FROM THE SALE OR USE OF THESE PRODUCTS. THIS DISCLAIMER APPLIES BOTH DURING AND AFTER THE TERM OF WARRANTY.**

**THIS WARRANTY IS EXPRESSLY IN LIEU OF ALL OTHER WARRANTIES, EXPRESS OR IMPLIED, INCLUDING THE WARRANTIES OF MERCHANTABILITY AND FITNESS FOR A PARTICULAR PURPOSE (EXCEPT AS MAY BE OTHERWISE PROVIDED BY LAW).**

**This warranty gives you specific legal rights, and you may also have other rights, which vary, from state to state.**

# **WARRANTY INFORMATION**

---

## **Warranty Service**

Better Packages will replace or repair (at the company's discretion) any defective parts within the warranty period, on a no-charge basis. The Authorized Distributor/Service Center will furnish, without charge, necessary labor to service the machine.

For service under this warranty, call or write your nearest Better Packages Distributor/Service Center or Better Packages, Inc. Ansonia, CT at 800-237-9151 (US only) or (203) 926-3700.

If customer wishes, with authorization from Better Packages or an Authorized Distributor/Service Center, a product may be shipped to Better Packages for warranty service. Any item shipped for warranty service must be shipped in the original factory carton and properly packed with the original protective packaging inserts or a secure carton that will properly protect the unit during transit. Any damage to machines or parts received improperly packed are the responsibility of the customer. All associated shipping or freight costs related to items shipped for service are the sole responsibility of the customer. Transportation charges on machines or parts returned to Better Packages for service must be prepaid by the customer. Customers will be responsible for freight expenses on parts or machines returned to them.

**Better Packages' ship-to address is:** 4 Hershey Drive, Ansonia, Connecticut 06401.

## **Warranty Registration**

Filling out the warranty card and returning it to us protects your warranty and allows us to keep you informed of product upgrades. Visit [www.betterpackages.com/warranty-registration](http://www.betterpackages.com/warranty-registration) to fill out the warranty card online.

# GENERAL INFORMATION

## Description of the 755e

The Better Pack 755e is an electric water-activated tape dispenser (also known as a paper tape dispenser, gummed or gum tape water-activated tape dispenser) made for a fast-paced packaging environment where random-sized heavy items are being shipped. This dispenser can handle tape up to 4 inches wide.

The BP755e is UL Listed by the independent safety certification company, Underwriters Laboratory. It is also CE and CSA certified and RoHS compliant. The 755e is equipped with a heater unit, water tank, and high capacity water bottle, 64oz (1.89 liter).

There are two primary models of the 755e. The 755eS, has an easy to use color-coded keypad with 20 preset tape lengths, and the 755eSA that uses two (2) knobs to select lengths and includes some automatic features.

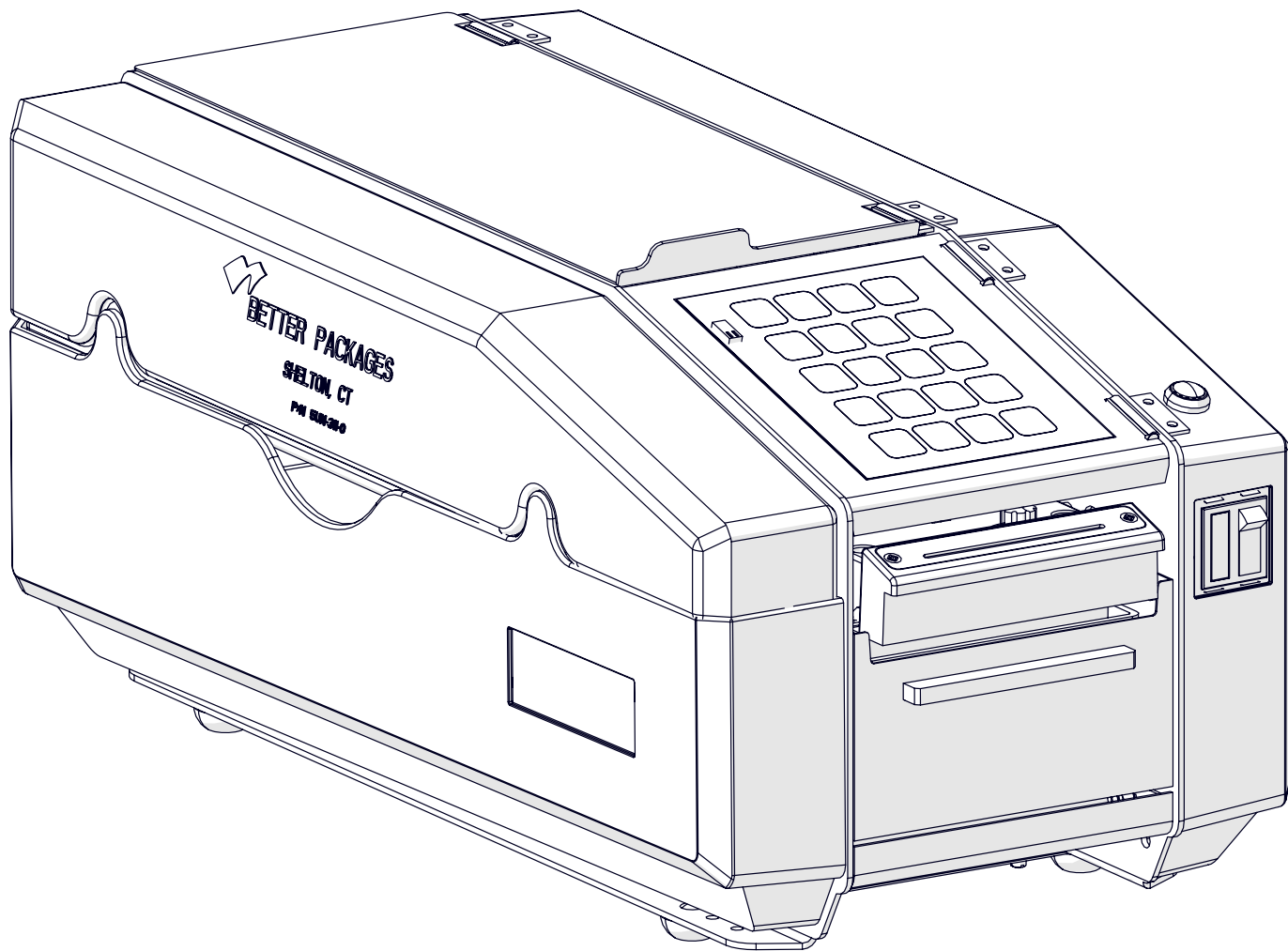

**Figure 1: Better Packages 755e**

## Definitions

Common terms that will be used throughout this manual.

**WAT** – IPG Brand Water Activated Tape

**User/Operator** – The individual who has been trained on the daily use of the Machine System

**Maintenance Champion** – The individual(s) who work for the end user of the Machine System who are responsible for conducting general and preventative maintenance

# **IMPORTANT SAFEGUARDS**

---

There are a number of safety labels used on the 755e. These labels are placed at different locations on the dispenser to warn operators and service personnel of possible dangers. Please read the labels on the machine and the following safety precautions before using the machine.

**Read this manual for other important safety operating and service information.**

**Only trained personnel are to operate machine.**

**Only fully qualified technicians are to service this machine.**

**Wear safety glasses when performing maintenance.**

**Allow time to cool before working on or near the heater.**

**Disconnect electrical power before servicing.**

**Follow Lock Out / Tag Out Procedures BEFORE servicing any machinery.**

**All factory installed covers and guards must be in place before operating.**

**Stay clear of moving parts which can shear and cut.**

Should any of the safety labels on the dispenser be damaged or destroyed, replacements can be ordered through your distributor.



# LABEL PLACEMENT



Located on inside panel



Located on inside of lid



Located on inside of lid

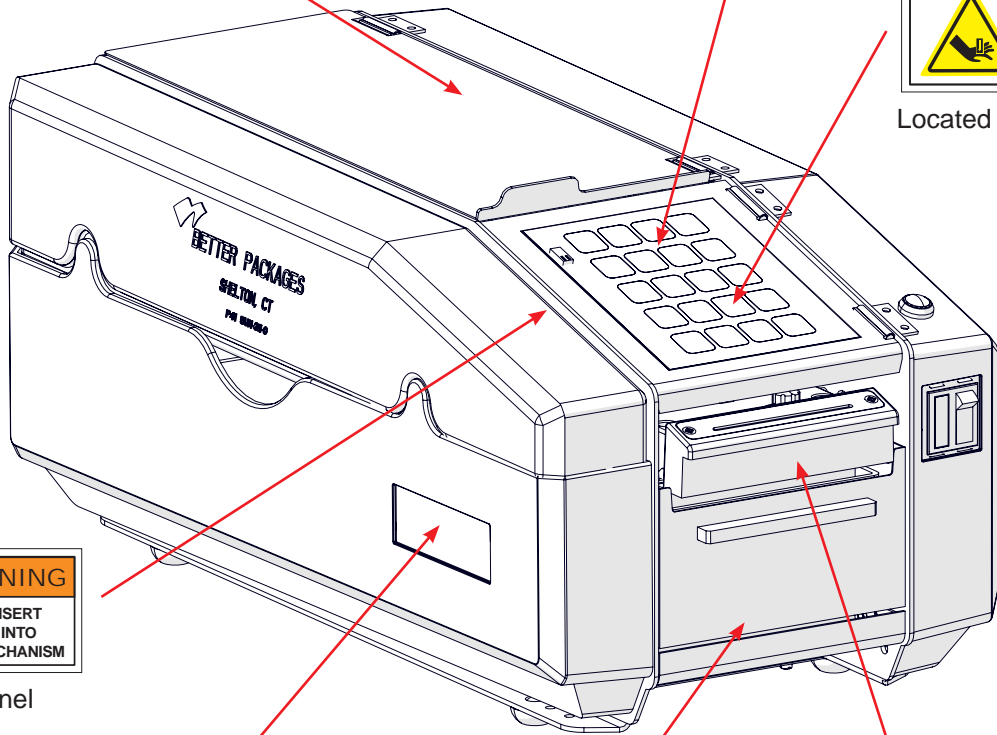

Located on inside panel







Located on water tank shelf



Figure 2: Label Placement

# LABEL DESCRIPTIONS

<p>The label shown is affixed to the heaters.</p> <p>It warns operators and service personnel to keep their hands clear of hot elements. Allow time to cool, minimum of 30 minutes, prior to servicing.</p> <p>Reorder number: <a href="#">9004150</a></p>	 <p><b>Figure 3: Hot Decal</b></p>
<p>The label shown is affixed to the inside of the keypad lid.</p> <p>It warns operators and service personnel to not use specific cleaners or lubricants.</p> <p>Reorder number: <a href="#">9002810</a></p>	 <p><b>Figure 4: Warning Hazard Decal</b></p>
<p>The label shown is affixed to the inside of the keypad lid, inside left frame, and on the water tank shelf.</p> <p>It warns operators and service personnel to not reach into the dispenser near the cutting blade. Disconnect all energy sources before servicing.</p> <p>Reorder number: 9004720</p>	 <p><b>Figure 5: Warning Cut Decal</b></p>
<p>The label shown is affixed to the sides of the machine.</p> <p>It is the model of the dispenser.</p> <p>Reorder number (Gum Side In): <a href="#">90046201</a></p>	 <p><b>Figure 6: Model Decal</b></p>
<p>The label shown is affixed to the inside right frame.</p> <p>It is the model and serial label. This will display model, power requirements, serial number, certifications, fuse rating, and manufacturer details.</p> <p>Reorder number: Please contact Better Packages Customer Service for the correct replacement for your machine as there are different models.</p>	 <p><b>Figure 7: Machine Nameplate</b></p>

Should any of the safety labels on the Case Sealer be damaged or destroyed, replacements can be ordered through your distributor.

# MACHINE NAMEPLATE

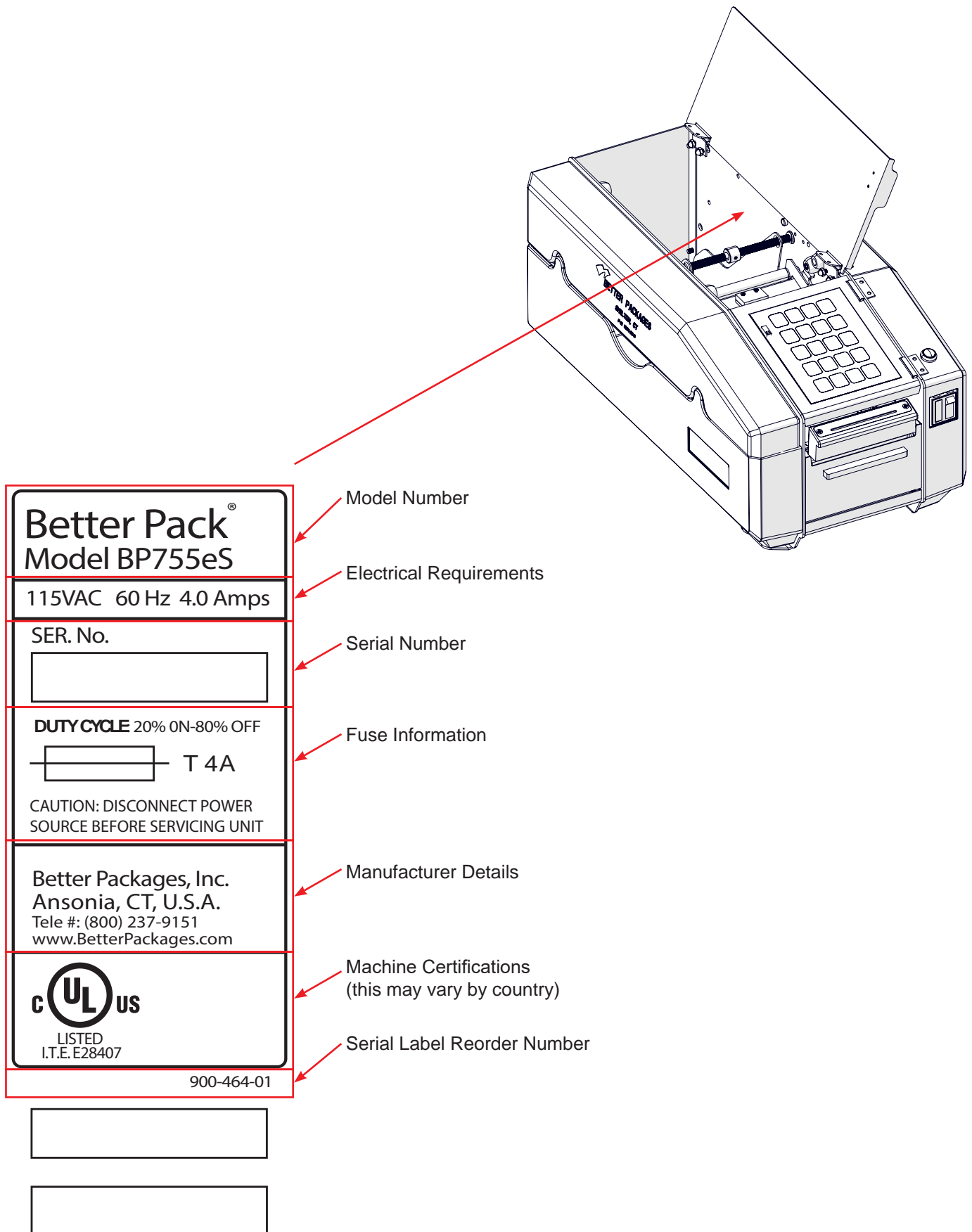

Figure 8: Machine Nameplate

# IMPORTANT SAFEGUARDS

---

## Explanation of Signal Word Consequences



**WARNING: INDICATES A POTENTIALLY HAZARDOUS SITUATION, WHICH IF NOT AVOIDED COULD RESULT IN DEATH OR SERIOUS INJURY OR PROPERTY DAMAGE**



**CAUTION: INDICATES A POTENTIALLY HAZARDOUS SITUATION, WHICH IF NOT AVOIDED COULD RESULT IN MINOR OR MODERATE INJURY OR PROPERTY DAMAGE**



### **WARNING**

- 1. To reduce the risk associated with mechanical, pneumatic, and electrical hazards:**
  - Read, understand, and follow all safety and operating instructions before operating or servicing the Dispenser
  - Allow only properly trained and qualified personnel to operate and service this equipment
- 2. To reduce the risk associated with pinches, entanglement, and hazardous voltage:**
  - Turn electrical supply off and disconnect before performing any adjustments, maintenance, or servicing the Dispenser
- 3. To reduce the risk associated with pinches and entanglement hazards:**
  - Turn the Dispenser off when not in use
  - Never attempt to work on any part of the Dispenser, load tape, or remove jammed tape from the Dispenser while the machine is powered on
- 4. To reduce the risk associated with hazardous voltage**
  - Position electrical cord away from foot traffic and vehicle traffic
  - Do not operate the Dispenser with a damaged power cord
- 5. To reduce the risk associated with sharp blades hazards:**
  - Keep hand and fingers away from the tape cutoff blades, the blades are very sharp
- 6. To reduce the risk associated with fire and explosion hazards:**
  - Do not operate this equipment in potentially flammable and/or explosive environments
- 7. To reduce the risk associated with muscle strain:**
  - Use proper body mechanics when moving or lifting the Dispenser
- 8. To reduce the risk associated with mechanical, pneumatic, and electrical hazards:**
  - Allow only properly trained and qualified personnel to operate and service this equipment



### **CAUTION**

- 1. To reduce the risk associated with pinch hazards:**
  - Keep hands, hair, loose clothing, and jewelry away from internal components



**CAUTION: TO AVOID INJURY THE MACHINE OPERATOR SHOULD REMAIN ATTENTIVE AND SHOULD NEVER REST THEIR HANDS, ARMS, HEAD, OR ANY OTHER BODY PART ON THE MACHINE.**



**WARNING: DISCONNECT THE DISPENSER FROM ALL ENERGY SOURCES AND ALLOW THE HEATER TO FULLY COOL BEFORE PERFORMING ANY MAINTENANCE TO THE DISPENSER.**

This equipment is not suitable for use in locations where children are likely to be present.

# IMPORTANT SAFEGUARDS

---

## Operator Skill Level Descriptions

These descriptions and levels are uniform across all Better Packages WAT Dispensers

### **Skill “A” Dispenser Operator**

This operator is trained to use the Dispenser with the machine controls, to change tape, clear jams, and perform basic troubleshooting.

**Important:** *The end user area supervisor must ensure that the operator has been properly trained on all dispenser functions before operating the dispenser.*

### **Skill “B” Mechanical Maintenance Technician**

Also referred to as the Maintenance Champion, this technician, is trained to use the Dispenser as the Operator and to check and adjust mechanical components, to perform maintenance operations and repair the Dispenser. A skill “B” operator is not allowed to work on live electrical components.

### **Skill “C” Factory Trained Technician**

A Skill “C” technician is trained by IPG and may perform extraordinary maintenance. This includes electrical components.

### **Operators skill level required to perform the following tasks on the Tape Head**

<b>OPERATION</b>	<b>MACHINE CONDITION</b>	<b>OPERATOR SKILL LEVEL</b>	<b>NUMBER OF OPERATORS</b>
Tape Roll Replacement	Powered Off	A	1
Feed Wheel Adjustment	Powered Off	A	1
Blade Replacement	Electrical Power Disconnected	B	1
Ordinary Maintenance and Preventative Maintenance	Electrical Power Disconnected	B	1

Better Packages offers a mail in factory maintenance program. Contact your Authorized IPG Representative for more information.

# SPECIFICATIONS

## 755e Dimensions

Dispenser Weight (without tape roll):  
33.5 lbs (15.2kg)

Shipping Weight:  
42 lbs (19kg)

Maximum tape roll diameter: 7.5in (190mm)  
Maximum tape roll length: Up to 600ft (183m)

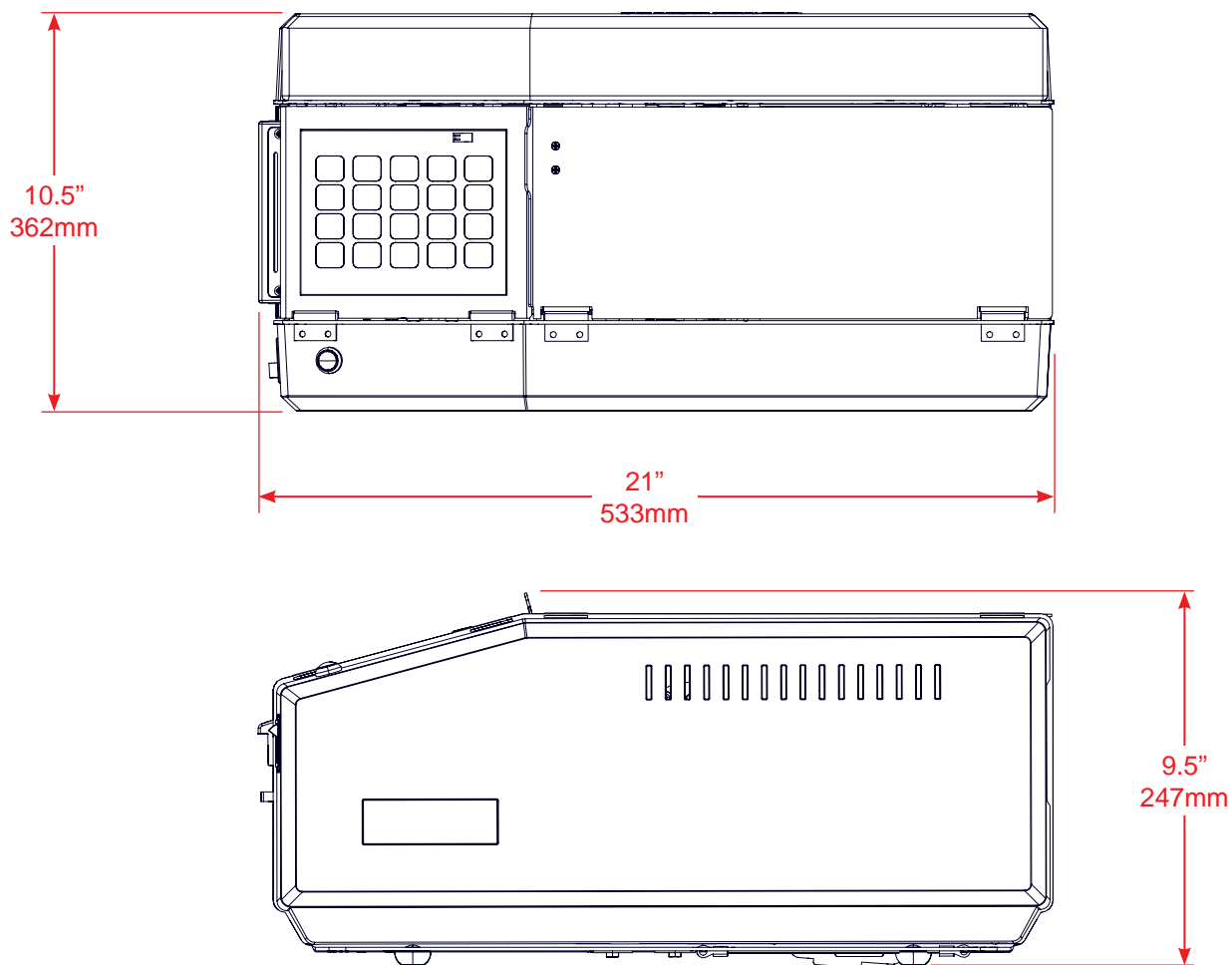

Figure 9: 755e Dimensions

# SPECIFICATIONS

## 755e Components

Keypad and Tape Basket Lids shown in open position.

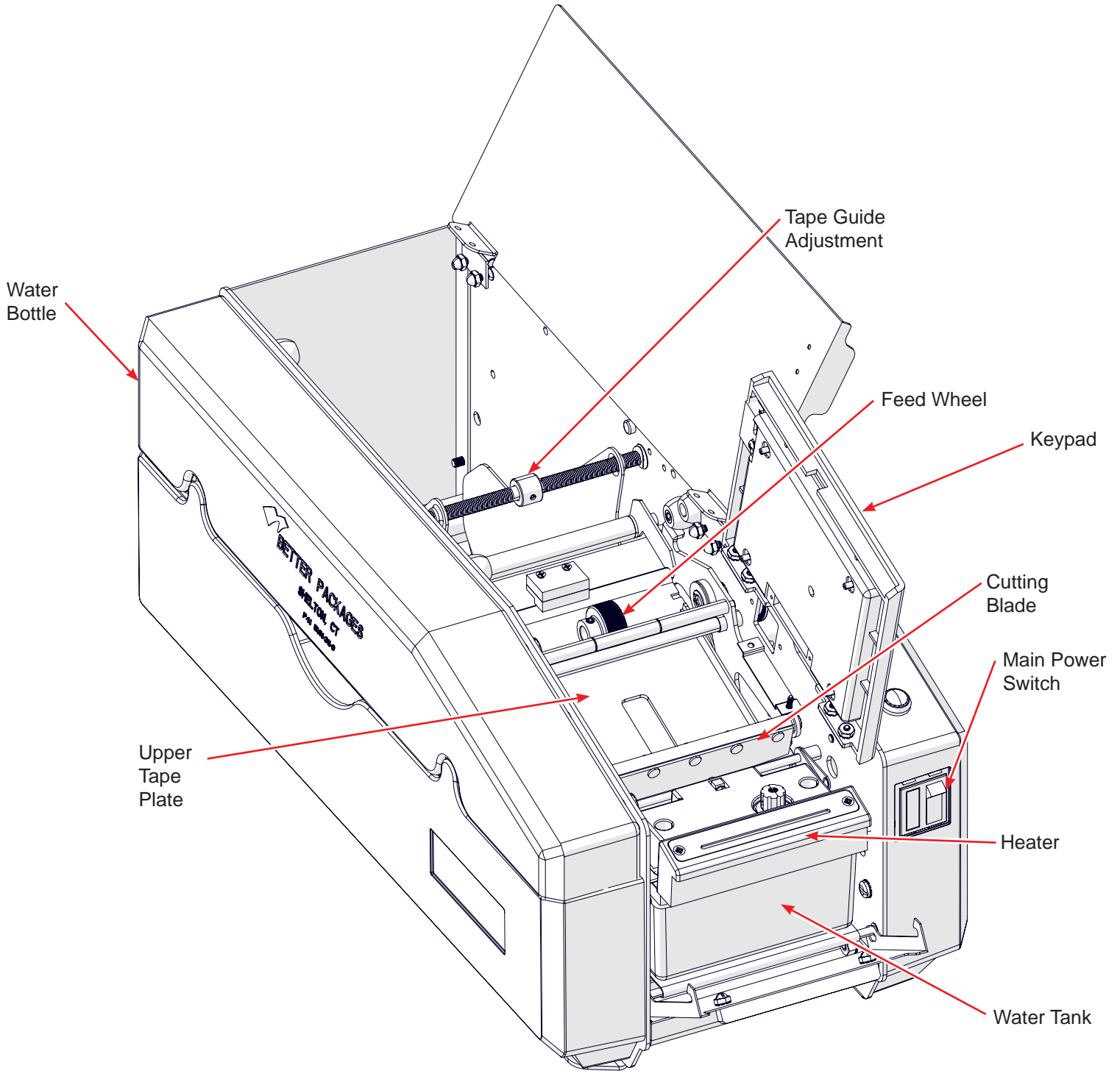

Figure 10: 755e Components

# **SPECIFICATIONS**

---

## **Operating Conditions**

Use in a dry, relatively clean environment at 40° to 105° F (5° to 40° C). Humidity not to exceed 90% at a temperature of 68° F (20° C). The 755e will be capable of operating correctly at altitudes up to 10,000 ft. (3,000 m) above sea level.

This dispenser is not designed to operate in a refrigerated or freezer environment.

## **Tape Requirements**

Use only IPG Brand Water Activated Tape.

Maximum tape roll length of 600 ft. long or 7.5" diameter roll of tape (182.5 meter long or 190mm diameter roll).

Minimum tape width: 1" (25.4mm)

Maximum tape width: 4" (101.6mm)

## **Technical Specifications**

Dispensing Speed: 32 inches (81.3cm) per second.

Water Bottle Capacity: 64oz (1.8 liter).

Power Requirements:

Always connect the 755e to a properly grounded outlet, that has been installed in accordance to all local codes and ordinances, using a power cord that has been provided by Better Packages.

<b>North America (US/Canada)</b>		
Model	Length/Unit of Measure	Power Requirements
BP755eS	Inches	115V 60Hz, 4A
BP755eSA	Inches	115V 60Hz, 4A

<b>Europe</b>		
Model	Length/Unit of Measure	Power Requirements
BP755eM	Metric	220V 50Hz, 2A
BP755eMA	Metric	220V 50Hz, 2A

<b>Japan</b>		
Model	Length/Unit of Measure	Power Requirements
BP755eJA	Metric	100V 50Hz, 4A

## **Tape Length**

- The 755eS comes standard to be able to dispense tape lengths from 6" to 75".
- The 755eSA comes standard to be able to dispense tape lengths from 6" to 100".
- The 755eM comes standard to be able to dispense tape lengths from 15cm to 190cm.
- The 755eMA comes standard to be able to dispense tape lengths from 15cm to 254cm.

The 755e series machines have the ability to dispense up to 120" (305cm) using the random button.



# SET-UP PROCEDURE

## Unpacking

After opening all the top flaps on the carton, you will find instructions for properly removing the dispenser and its included materials. It is recommended to keep all packing materials in case you need to ship the dispenser later or wish to pack and store it.

## Verifying the Contents

Once the dispenser has been removed from the carton verify it has been shipped with all of the following items.

- Wetting Brush Qty 2 Part Number: TS-37
- Water Tank Qty 1 Part Number: 5UN-033-0
- Water Bottle Qty 1 Part Number: 5UN-311-0
- Upper Tape Plate Qty 1 Part Number: 5UN-037-0
- Power Cord Qty 1
- User Manual Qty 1

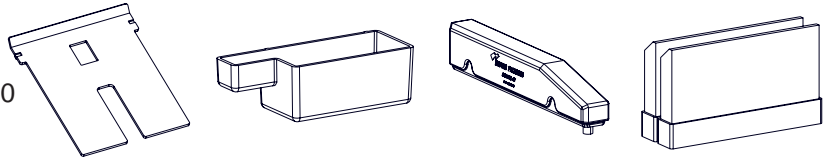

The power cord included will be for the region/country your unit is sold into.

**Figure 11: Included Components**

## Adjusting the Roll Guides

Roll guides on the 755e series machines are preinstalled on a screw drive mechanism. Rotating the dial towards the front of the dispenser will bring the roll guides tighter, to a minimum of 1in. Rotating the dial towards the rear of the dispenser will open up the roll guides, to a maximum of 4in. The bottom of the guides are designed to fall into precut slots in the bottom of the tape basket. These slots are cut at widths corresponding to standard tape width offerings. The roll guides will need to be angled up and out of these slots prior to adjusting.

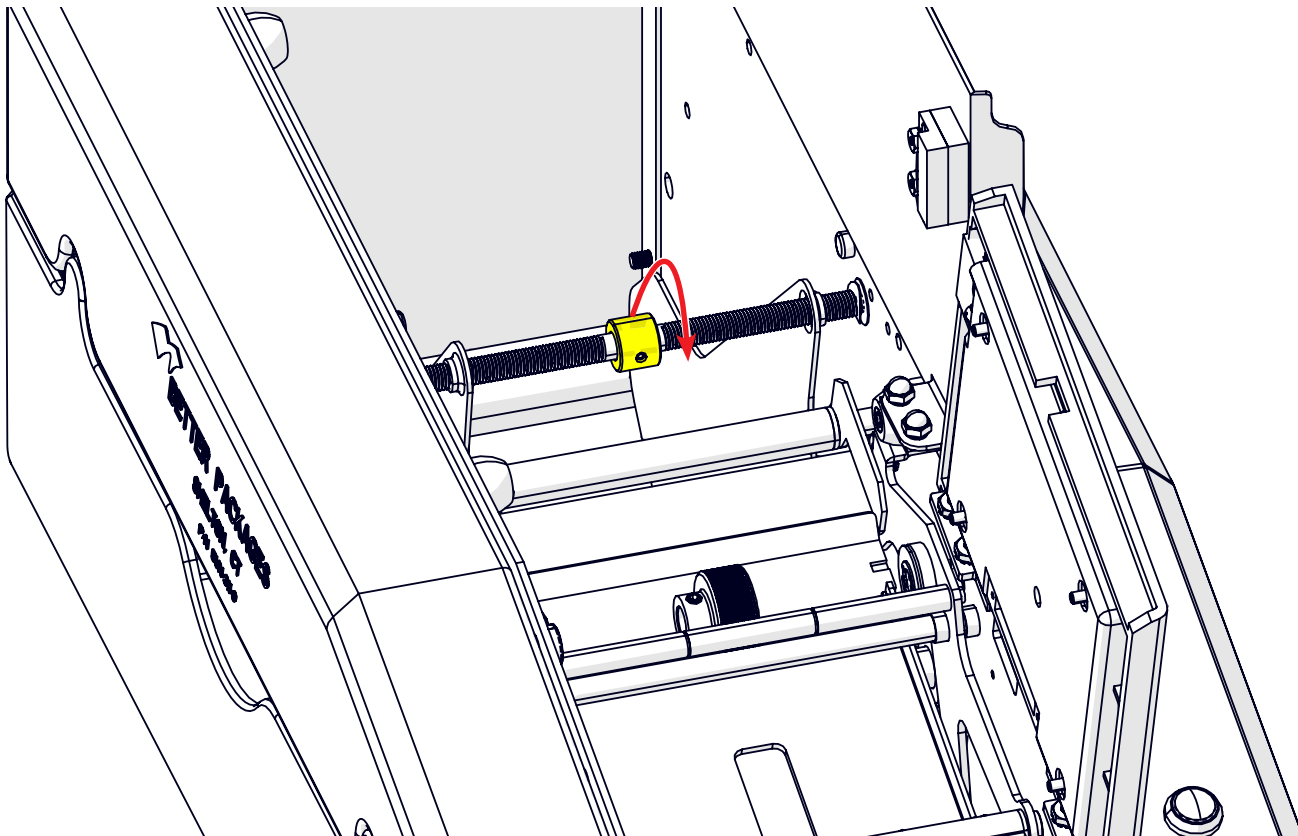

**Figure 12: Roll Guides**

# SET-UP PROCEDURE

## Loading the Tape Gum Side In

The loading procedure is for all 755e models

1. Open the **Keypad Lid**
2. Open the Tape **Basket Lid**
3. Using scissors cut the end of the tape so it is a square clean cut
4. Adjust the **Roll Guides** if necessary
5. Place the roll in the **tape basket** so that:
  - The roll is vertical
  - The cut end comes from under the roll and over the back
6. Feed the tape over the **Black Roller**
7. Slip the tape under the **Upper Tape Plate** and under the **feed wheel**. The tape should rest up to the **blade**
8. Close the lids

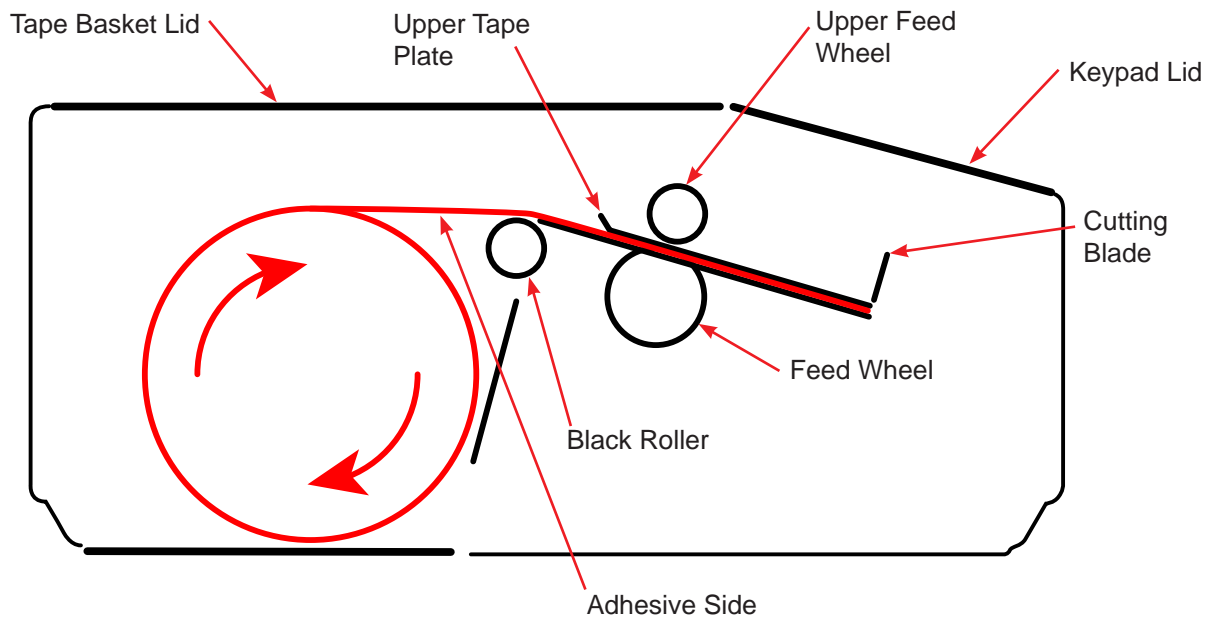
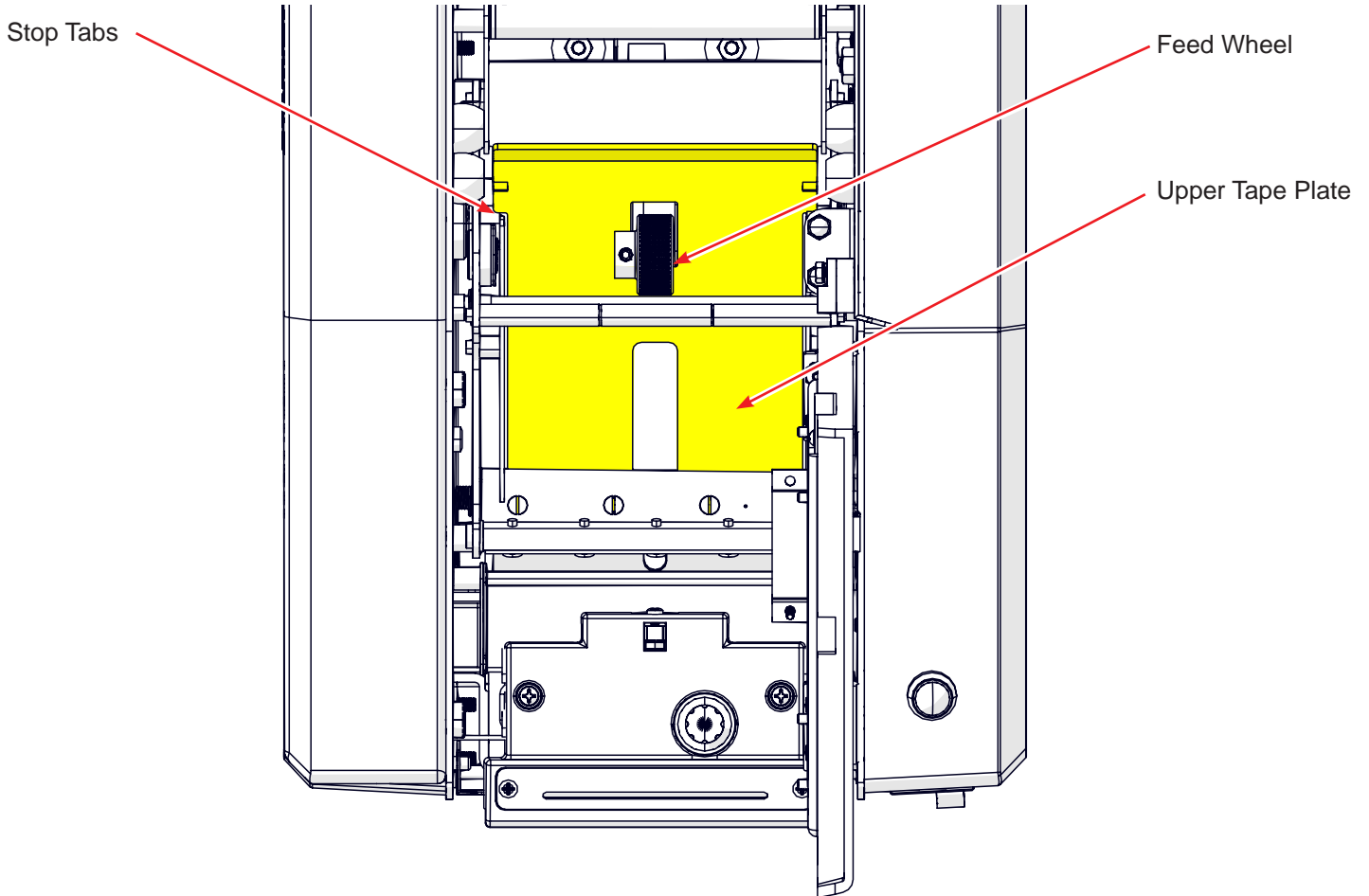

**Figure 13: Tape Threading Diagram**

# SET-UP PROCEDURE

## Checking the Upper Tape Plate

Verify the upper tape plate is completely installed and in the proper position. If the tape plate is not in proper position remove it by grasping the bent rear portion and sliding it all the way to rear of the dispenser, then lift the rear end up just over the tape guide adjustment screw. Verify the tape path is clean and dry before sliding the upper tape plate back into position. It should rest under the upper feed wheel with the tape plate stops resting against the side walls of the lower tape plate.



**Figure 14: Upper Tape Plate**

The Upper Tape Plate is vital for the functionality of the Dispenser. If the plate is not in position or is missing the tape will jam.

# SET-UP PROCEDURE

## Installing the Brushes and Water Tank

The 755e dispenser takes two (2) independent brushes placed in the water tank. To install the brushes:

1. Orient the brushes in the proper direction with the shortest bristles closest to the Dispenser.
2. Place the brushes in the opening allowing them to rest against the molded sections of the water tank.
3. The brushes are properly installed when the bristles are flat across the top of the tank.

755e brushes are held in by gravity.

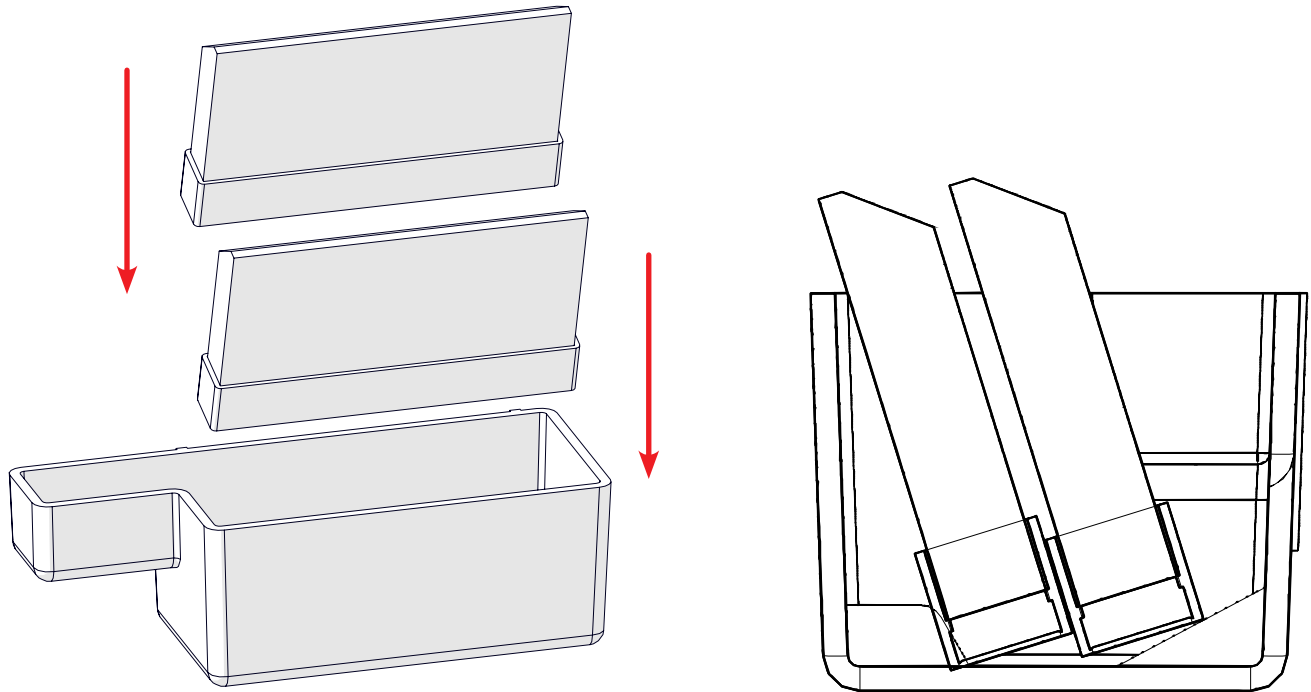

**Figure 15: Installing the Brushes**

## Adjusting the Water Level

Water level can be adjusted with a thumb screw in the hole under the opening in the water bottle. Loosen the thumb screw and raise or lower the metal tab to adjust the water level.

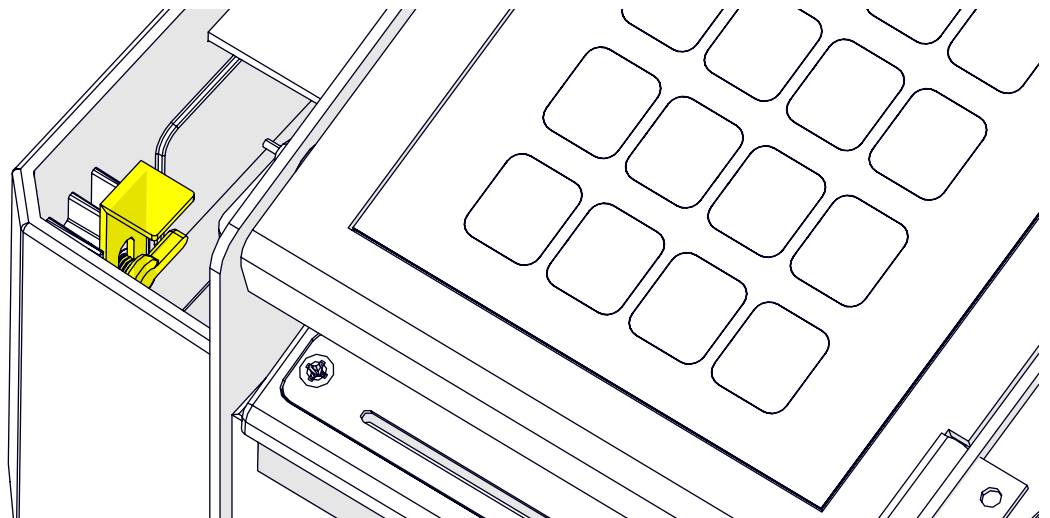

**Figure 16: Water Level Adjustment**

# SET-UP PROCEDURE

## Water Tank Install



**CAUTION: UNDER NORMAL OPERATIONAL CONDITIONS THE BOTTOM OF THE HEATER WILL BE HOT. HANDLE THE HEATER ONLY BY USING THE FRONT GRIP LIP OR ALLOW TIME FOR THEM TO FULLY COOL BEFORE HANDLING.**

1. Open the keypad cover to expose the heater.
2. Raise the heater, be sure to only grip the heater from the front lip.
3. Insert the left end of the water tank (fill area) through the small hole in the left side of cavity.
4. Rotate the right side of the water tank onto the tank shelf. Be sure it is pushed flush to the rear of the tank shelf.
5. Place the water bottle onto the dispenser. If the water tank is empty it will begin to fill.
6. Lower the heater onto the brushes, allowing it to rest on the top of the brushes.
7. Close the Keypad cover.

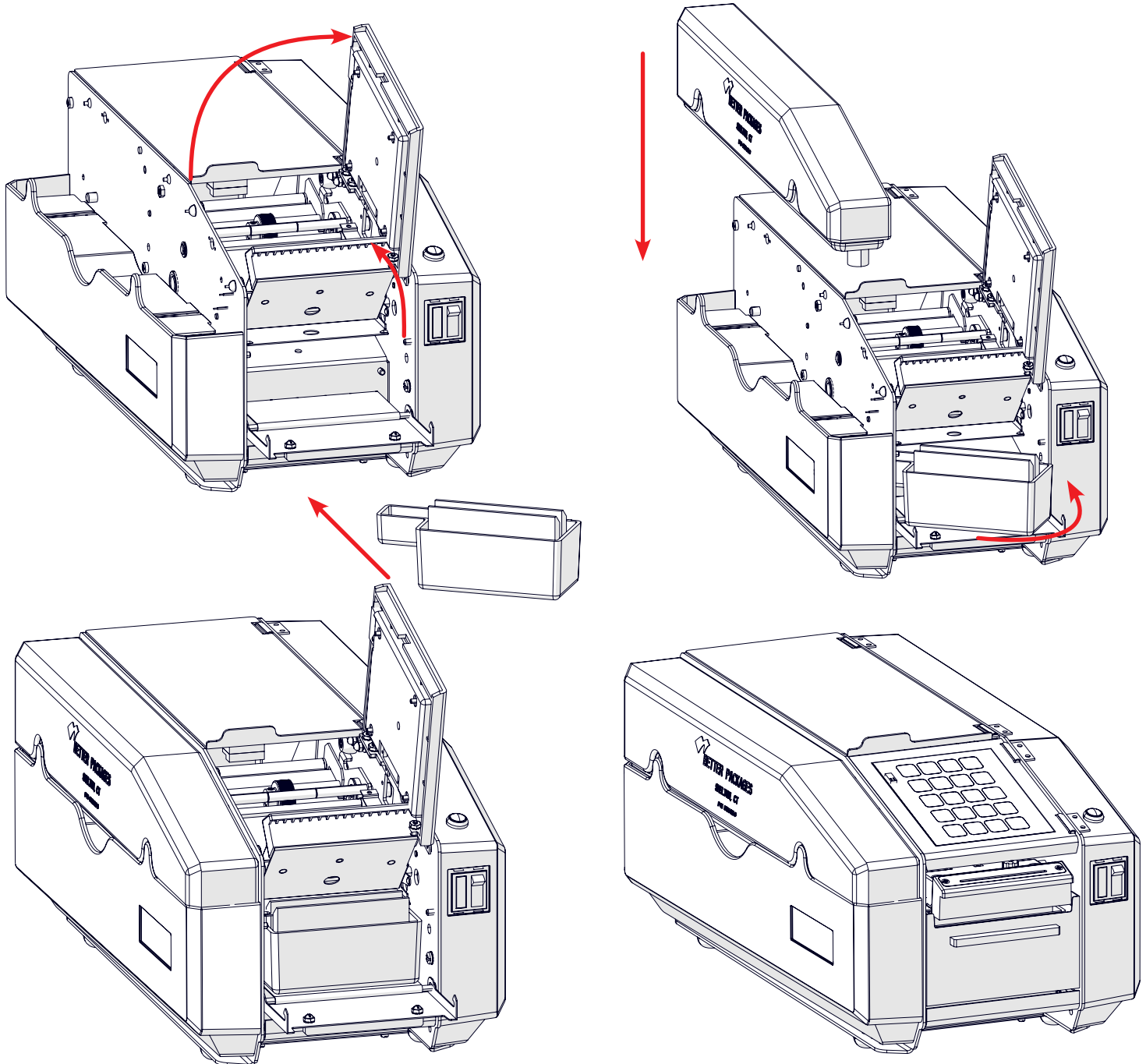

Figure 17: Installing the Water Tank

# SET-UP PROCEDURE

## Water Bottle Install

The 755e series machines all use the same 64oz (1.8 liter) water bottle. For best results fill it with room temperature water. There is no need for any special water, such as distilled water. In the event your facility has hard water or water with a higher than normal mineral count you may want to consider using filtered water.

The water bottles on the 755e dispensers do not have a bottle cap. When installing a full water bottle on the machine it is best to hold it upside-down right next to the water bottle support tabs. Place a thumb over the opening in the water bottle. Rotate the bottle just over the support tabs. In one motion remove your thumb from the opening and place the water bottle onto the water bottle shelf so the spout of the bottle is inside the water tank. Water will flow into the tank until it reaches the opening in the water bottle, forming a seal.

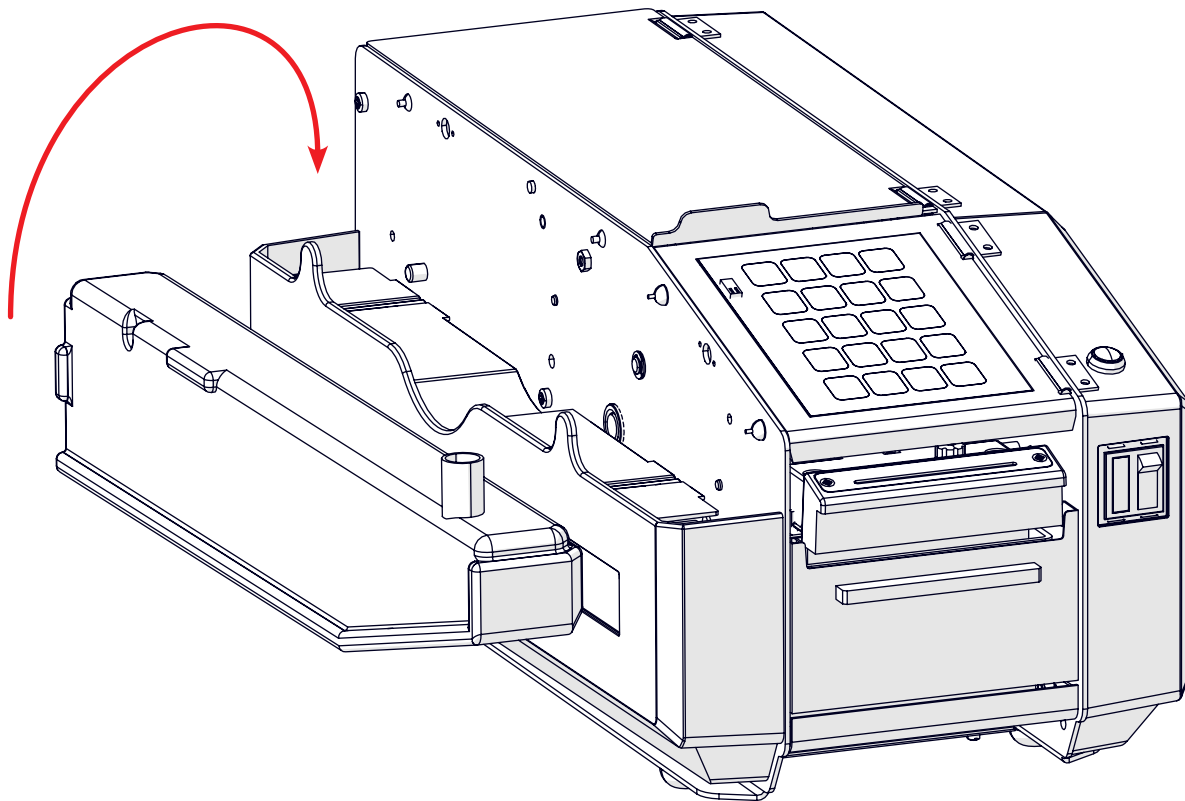

**Figure 18: Water Bottle Install**

# SET-UP PROCEDURE

## Connecting Power and Utilities

The 755e series machines come equipped with a three (3) pin power socket that is capable of accepting a variety of power cords for use around the world. The Dispenser is also equipped with a fuse holder.

There are four models of the 755 that are manufactured for world wide use. See the Technical Specifications section for which model is rated for your power requirements. To connect the Dispenser to power first verify the main power switch is in the Off [O] position, then insert the female end of the cord into the A/C Power Socket, then insert the male end into a properly grounded power outlet, lastly flip the main power switch to the On [I] position. The machine will beep when fully booted.

Only replace the fuse with a fuse supplied by Better Packages. Replacement part numbers:

755eS and eSA models use the ST2341K 4A fuse  
755eM and eMA models use the ST2490 2A fuse

Always use a power cord that has been supplied by Better Packages.



**WARNING: DO NOT TOUCH THE METAL PINS ON THE BACK OF THE MACHINE OR ON THE POWER PLUG AFTER OPERATING THE EQUIPMENT.**

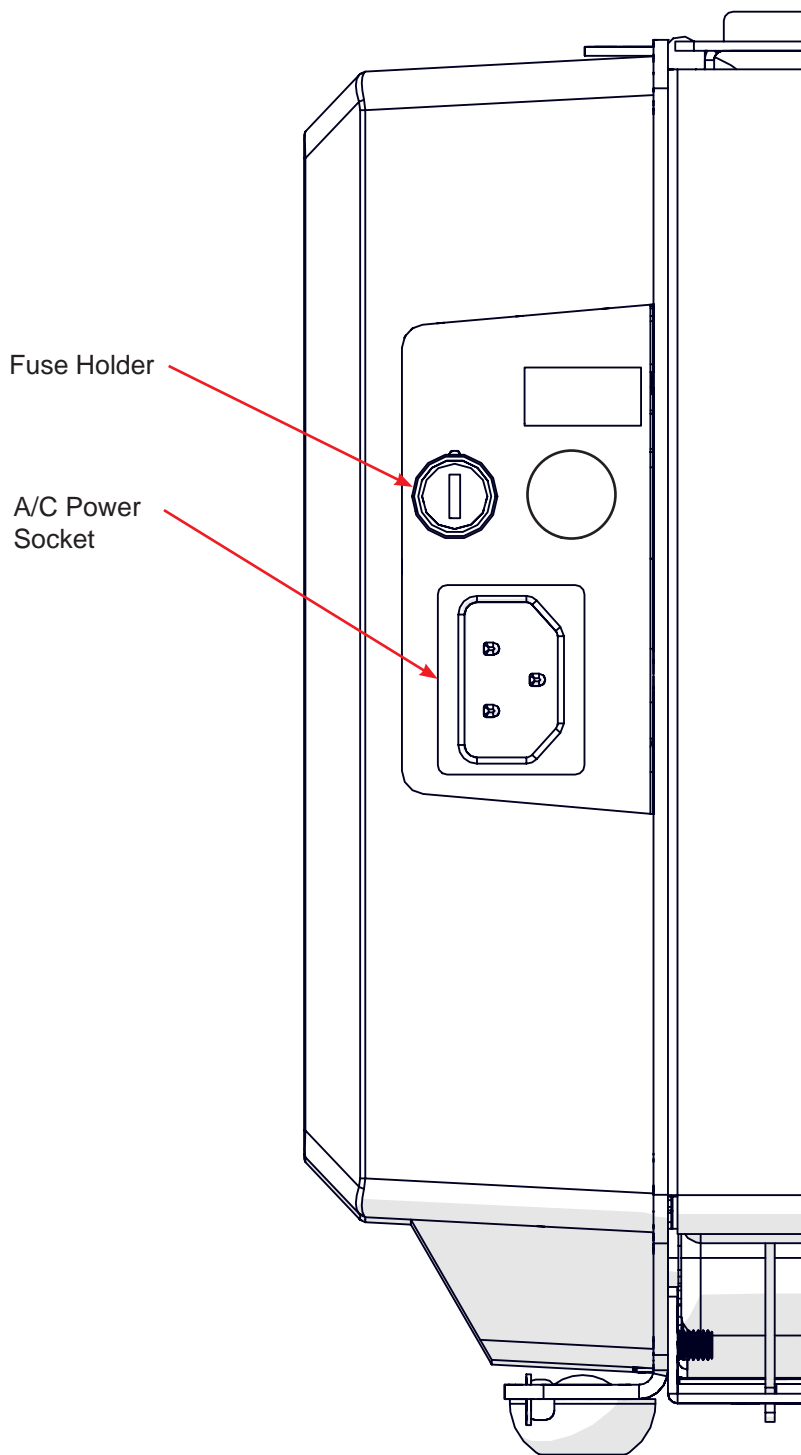

Figure 19: Power Panel



**CAUTION: ALL METAL PARTS ON THE DISPENSER ARE ELECTRICALLY GROUNDED. IT IS REQUIRED TO USE A PROPERLY GROUNDED POWER OUTLET THAT HAS BEEN INSTALLED BY A PROFESSIONAL.**

# SET-UP PROCEDURE

## Setting and Adjusting Temperature



**CAUTION: UNDER NORMAL OPERATIONAL CONDITIONS THE BOTTOM OF THE HEATER WILL BE HOT. HANDLE THE HEATER ONLY USING THE HEATER GRIP ON THE FRONT LIP OF THE HEATER OR ALLOW TIME FOR THEM TO FULLY COOL BEFORE HANDLING, AT LEAST 30 MINUTES.**

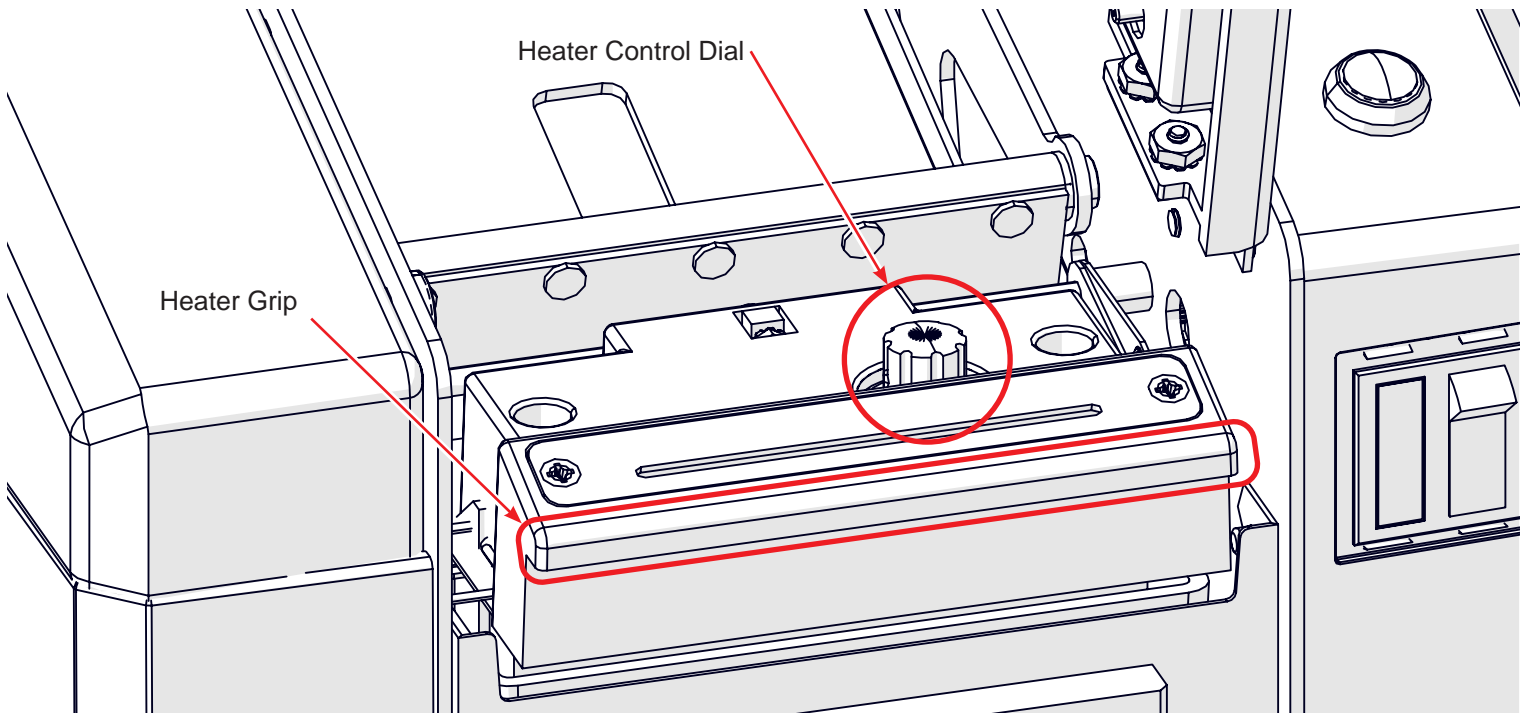

**Figure 20: Heater Adjustments**

The 755e series machines use the same style heater unit. The heater is accessible by lifting the keyboard console assembly. The heater is adjustable through a knob on the top of unit. It is marked with an OFF and HIGH to allow for easy setting. The Dispenser is shipped with the heater in the OFF [O] position.

Rotate the dial to the desired the heat setting. The heater setting is dependent on the environment the Dispenser is in. If the Dispenser is in a climate controlled space, the heater will not need to set higher than 50%. This will help extend the life of the heater.



# OPERATION

## General Operating Procedures

Verify the Dispenser is plugged into a properly grounded outlet. If the power cord is not connected to the Dispenser verify the main power switch is in the off position before connecting the cord to the rear of the Dispenser prior to plugging it into an outlet. See the section titled Connecting Power and Utilities for more details.

Verify tape is loaded correctly. If no tape is loaded see the section titled Loading the Tape for more details.

1. Flip the main power switch. After the machine successfully boots you will hear an audible beep giving the operator an audible alert that the machine is ready for use.
2. Adjust the heaters to the desired setting.
3. Select the desired output on the keypad.

## Selecting the Length of Tape 755eS and 755eM

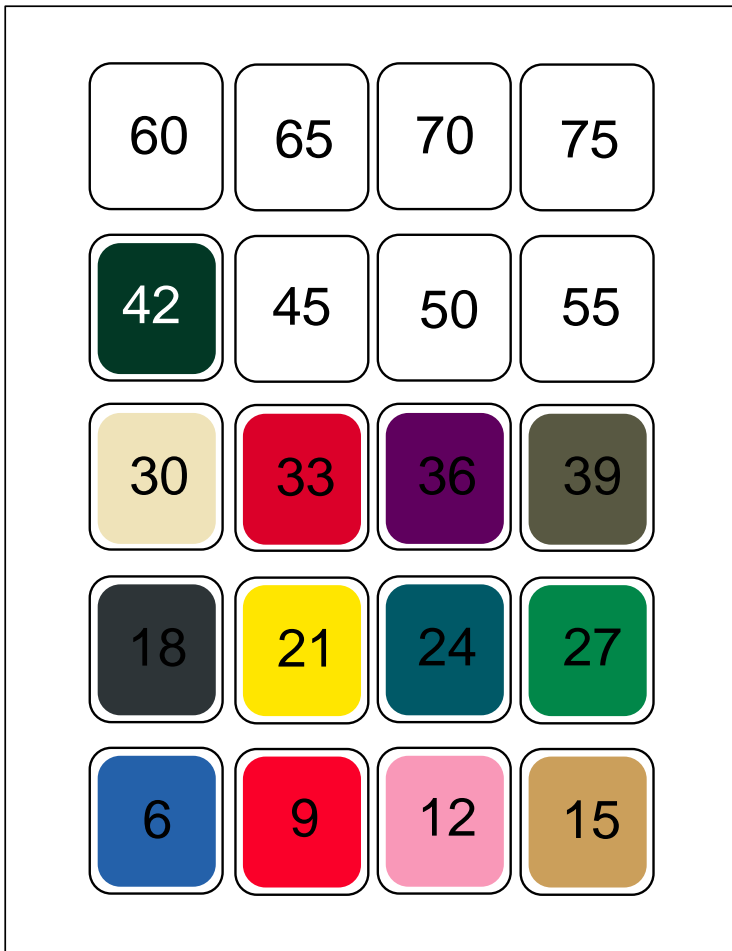

The 755eS keypad is an array of 20 preset length options from 6" to 75". The 755eM keypad is an array of 20 preset length options from 15cm to 157cm. The operator only needs to press the button for the desired length.

Each press of the keypad will dispense a single strip of tape.

**Figure 21: 755eS and 755eM Keypad**

# OPERATION

## Selecting the Length of Tape 755eSA and 755eMA

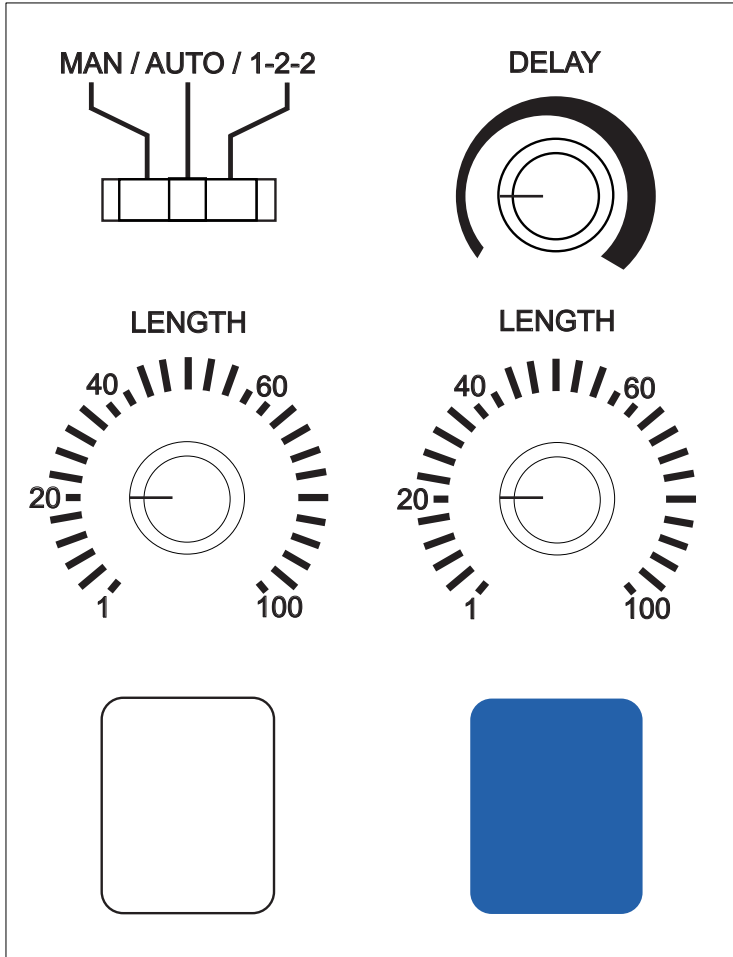

Figure 22: 755eSA and 755eMA Keypad

### Random Button

All models of the 755e have a “Random” button on the right side frame next to the keypad. This button will continuously dispense tape for as long as it is held down. With practice an operator can utilize this button to quickly and accurately dispense tape for their cases.

The 755eSA and 755eMA have a mode selector switch for Manual, Automatic, and 1-2-2 for easy “H” patterns. The Delay dial is used in automatic and 1-2-2 modes it controls the delay after a piece of tape has been removed before the 755 dispenses the next strip. The delay is helpful to allow operators time to handle cartons. Setting the delay dial to its minimal will instantly dispense the next strip. Two length selector dials each with a corresponding button, white and blue.

The 755eSA and 755eMA ship in manual mode. To engage manual mode use the selector switch and set it to the far left position. Use the dials to set the desired length then the white or blue button will dispense the selected option for the dial above it. They may be set independently for a pair of commonly used lengths.

To engage the automatic mode of the 755eSA and 755eMA use the selector switch in the upper left and click it into the center position. When in this position set the length dial to the desired length then adjust the Delay dial to add a pause in the sequence.

To engage 1-2-2 mode flip the selector switch to the far right position. In 1-2-2 mode the dial above the white button will dispense the first length in the sequence, this is typically for the sealing the center seam of the carton. If the delay dial is adjusted a delay will be incorporated in-between each dispense. The dial above the blue button will dispense the second and third lengths in the sequence. This mode is useful for anyone looking to seal their cases in an “H” pattern. After the third dispense in the sequence the 1-2-2 mode will start over.

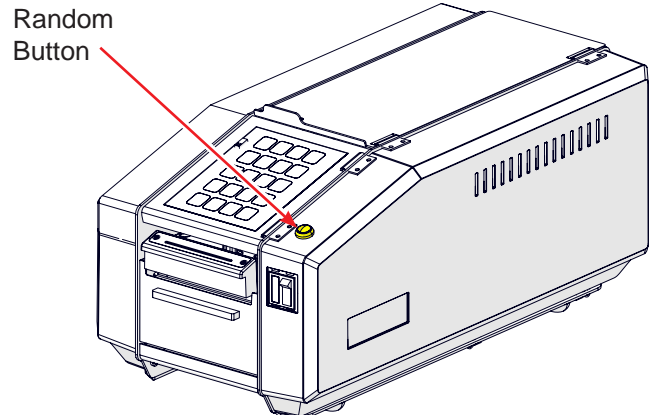

Figure 23: Random Button

# APPLYING TAPE TO A CARTON

---

## Choosing the Correct Tape Type

TYPE	CHARACTERISTIC
Paper Tape or Kraft Paper Tape	Made from paper only, with no additional reinforcing material
Reinforced Tape or Reinforced Paper Tape	Made from paper and contains additional strands of reinforcing material, typically fiberglass

IPG offers a variety of different grades of Paper Tape or Kraft Paper Tape. In most circumstances this non-reinforced tape is good for smaller and lighter cartons.

IPG offers a variety of different grades of Reinforced Tape or Reinforced Paper Tape. In most circumstances this reinforced tape is good for larger boxes and those with increased weight.

Contact your Authorized IPG Representative for the best tape for your applications.

## Choosing the Correct Tape Length

In most situations it is recommended to dispense a length of tape that is equal to the length of seam on the carton with an additional 4-6" (101-152mm) to allow for tape legs on either end of the carton.

In the event the carton is extremely long, longer than 24", an additional 6-8" (101-203mm) is recommended for tape legs.

In the event the carton is short an additional 3-4" (76-101mm) is may be used in place of the standard 4-6" (101-152mm).

## Proper Tape Moistening

Dispense a piece of tape and examine the adhesive surface. The tape should:

- Be evenly wet
- Have no dry spots
- Have no spots where water is running off the surface.

Rub the wet adhesive with your finger.

- The adhesive should have an "oily" feel and consistency.
- You should be able to move the adhesive underneath your finger.

When you rub two wet adhesive surfaces of the tape together against each other, you should see "strings" of adhesive stretching between the two surfaces as you pull them apart, looking much like taffy as it is pulled.

If the tape is too wet or watery, it:

- Will not set fast enough
- May slip slightly over the surface of the carton, causing a "loose" seal
- If the tape is not wet enough, it:
  - May be tacky or sticky like pressure sensitive tape, but not "oily" like properly moistened tape.
  - Is too dry to properly activate the adhesive which will prevent a permanent bond from forming (because the adhesive cannot penetrate the corrugate fibers).
  - May too easily pull off the carton during handling and transportation.

# APPLYING TAPE TO A CARTON

## Sealing the Carton

Based off of use by many operators the best way to apply the tape to the carton after it has been dispensed is:

1. Grip the tape from the sides.
2. Place the wet tape on the end of one of the flaps to be sealed so that:
  - Half of the tape's width is on one flap
  - The other half is overhanging
3. Fold the flap without the tape down to its closed position.
4. Fold the other carton flap (the one with the overhanging tape) down into its proper closed position so that the overhanging portion of the tape is now in contact with the other flap on the opposite side of the carton.
5. Starting from the middle of the carton, apply a light downward pressure and wipe your hands over the tape on top of the carton flaps. Move from the center to the sides and then down over the overlapping ends in the sides of the carton. Sometimes wiping the tape down a second time before releasing the carton is helpful

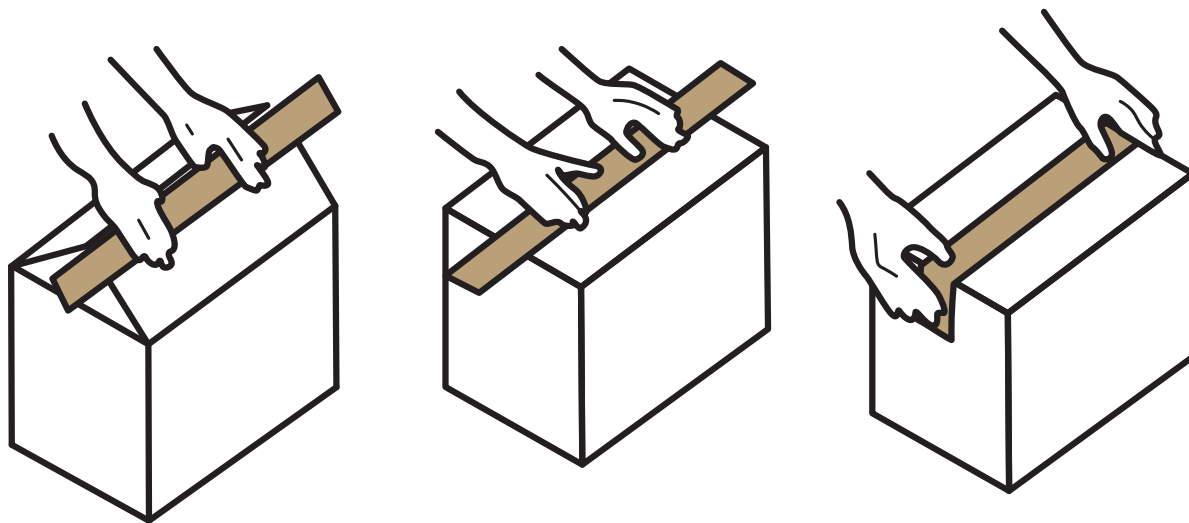

Figure 24: Applying the Tape

## Common Tape Patterns

The following are commonly used tape patterns. **“H” pattern** or sometimes referred to as the **“I” pattern** is when the center seam is sealed as normal and two more strips of tape are applied to seal the sides of the minor flaps. This allows for a secure and aesthetically pleasing carton. The **“Belly Band”** is when a strip of tape is placed in the opposite direction of the center seam. This helps secure heavier loads and is applied to the top and bottom of the box. The **“X” pattern** is more rarely used but is considered the most secure and is a cross between the “H” pattern and the “Belly Band.” It is used for extremely heavy items.

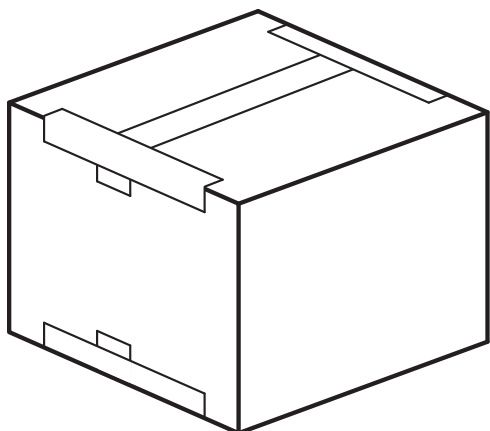

Figure 25: “H” Pattern

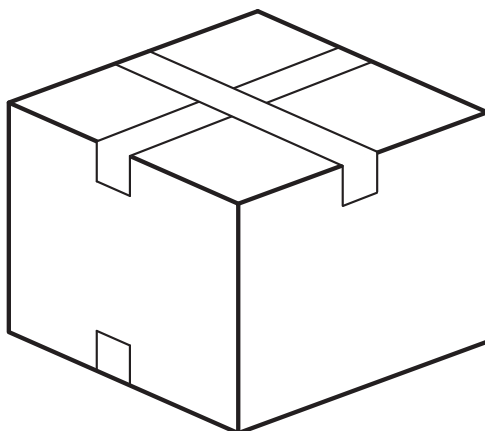

Figure 26: Belly Band

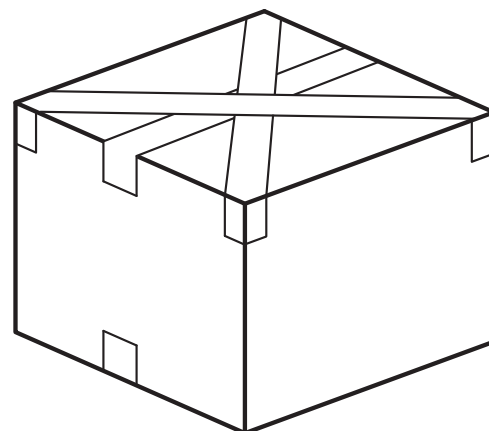

Figure 27: “X” Pattern

# PREVENTATIVE MAINTENANCE

## Suggested Preventative Maintenance Schedule



**WARNING: TURN OFF ELECTRICAL POWER SUPPLY BEFORE PERFORMING MAINTENANCE. THE CUT-OFF BLADE IS EXTREMELY SHARP USE CUT RESISTANT GLOVES WHEN SERVICING OR REPLACING THE BLADE. THE HEATER WILL BE HOT. ALLOW TIME TO COOL PRIOR TO SERVICING.**

### Weekly

- Wash brushes with mild soap and water. Rinse well to remove all soap residue.
- Clean any accumulated dust with a dry brush or blower.
- Wash water tank with mild soap and water. Rinse well to remove all soap residue.

### Monthly

- Clean accumulated glue from blades using a scraper. Do not scrape the cutting edge of the blade this can cause damage and may result in needing to change the blade or result in poor tape cutting.
- Apply a light coating of a light machine oil to the back of the blade. If the dispenser is being used in an area where the packaging of food consumables is done a food grade multipurpose oil should be used.
- Add only a few drop of a light machine oil to felt pads. If the dispenser is being used in an area where the packaging of food consumables is done a food grade multipurpose oil should be used.

### Annually

- Thoroughly clean all accumulated pieces of tape, dust, and any other foreign material from inside the Dispenser with a dry brush or blower.
- Clean the bottom of heaters and pressure plates of accumulated tape adhesive.
- Clean all covers with a damp rag.

## Washing the Tank, Brush, and Bottle

**Water Brush:** Glue from the tape may accumulate and reduce the effectiveness of the moistening system. Wash brushes weekly with mild soap. Be sure to agitate the bristles while in the soap and water solution. A brush is considered clean after this agitation and all adhesive build up has been removed.

It is recommended to soak brushes in a solution of mild soap and water daily overnight. This will reduce any adhesive build up and extend the life of the brushes.

If you operate multiple machines all brushes may soak in the same container.

Rinse the brushes in running warm water before reinstalling them into a clean water tank.

**Water Tank:** Glue from the tape may accumulate in the water tank. This build up can accumulate in the water brushes and result in a reduction of water transmission to the tape and a weaker bond to the carton.

It is recommended to wash the water tank once a week in a warm soap and water solution. Use a low-scratch abrasive brush to clean the bottom of the water tank as well as the tight areas. Rinse the water tank in running warm water before reinstalling.

**Water Bottle:** Hard water build up may appear in the water bottles over time. If you have hard water or other mineral rich water it is recommended to use a filtered water to extend the life of the water brush as well as the seal in the water bottle cap.

It is recommended to wash out the water bottle once a week with a warm soap and water solution. Fill the bottle  $\frac{1}{4}$  to  $\frac{1}{2}$  with the soap and water solution. Secure the water bottle cap, then shake the bottle vigorously. Allow the bottle to drain before rinsing with warm water. Allow the water bottle to fully dry before reusing.

In extreme circumstances the water bottle may be cleaned with a white vinegar and water solution but it would be recommended to replace the water bottle and its cap.

The adhesive is non-toxic and water soluble. If adhesive builds up on an operator's hands, washing with soap and water will remove any debris. Standard packing gloves or other required PPE should be used in accordance with plant policies where the dispenser is being operated in.

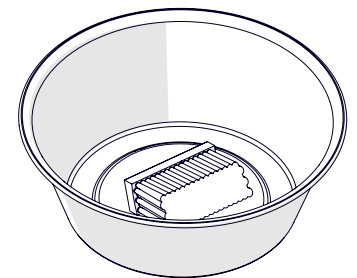

**Figure 28: Brush Cleaning**

# TROUBLESHOOTING

PROBLEM	POSSIBLE CAUSES	SOLUTIONS
Tape is too short	Feed wheel is out of adjustment	Conduct a feed wheel check and adjustment.
Tape is too long	Damaged encoder wheel	Remove left side cover and verify the integrity of the encoder wheel.
Dispenser not outputting tape	Dispenser is unplugged	Verify the power cord is connected to the Dispenser and a properly functioning grounded outlet.
	Dispenser is off	Flip the main power witch to the ON position.
	Safety interlock system is interrupted	Verify the lid(s) of the Dispenser are closed.
		Verify the magnet in the lid(s) is in place. Verify the lid is properly closed and not skewed.
	Fuse is blown	Replace the main fuse. Use a fuse rated at AL T2 250V. For eS and eSA <a href="#">ST2341K</a> For eM and eMA <a href="#">ST-2490</a>
	Keypad is disconnected	Open the keypad cover and verify the data ribbon in intact.
Main Board is damaged	Verify the Dispenser is connected to a working outlet and plugged in, flip the main power switch to the ON position, the Dispenser should have an audible beep. If there is no beep the Main Board will need replacement.	
Poor tape wetting	Low water level	Adjust the height of the Water Bottle using the slider on the Water Tank.
	Dirty application brushes	Soak the brushes in warm water and clean with mild soap.
	Tape is not making contact with the brushes	Verify the heater is properly mounted and not damaged.
	Water Bottle empty	Refill the Water Bottle

The following is a list of parts that is recommended to keep on hand.

Description	Item Number	QTY
Brush	TS-37	2
Upper Tape Plate	5UN-037-0	1
Fuse*	4A ST-2341K	1
	2A ST-2490	
Upper Feed Wheel	5UN-018-0	1

\*4A fuse is for eS, eSA, eJA | 2A fuse is for eM, eMA

If you are experiencing trouble with your Dispenser or it is functioning in a way that is not consistent with this manual please contact IPG Machinery Support at +1 813-345-3070 between the hours of 8am and 7pm Eastern Standard Time or via email at [machsupp@itape.com](mailto:machsupp@itape.com).

# USER NOTES

---

